

Unit Certificate

FOXESS CO., LTD.

No.939, Jinhai Third Road, New Airport Industry Area, Longwan District,
Wenzhou,
China

Type of unit	Microinverter (Typ 2)	
Description of unit	M1-600-E, M1-800-E, M1-1000-E, M1-1200-E	
Technical data	Rated active power: $P_{rE} = 600 - 1200 \text{ W}$ Max. active power: $P_{E_{max}} = 600 - 1200 \text{ W}$ Max. apparent power: $S_{E_{max}} = 600 - 1200 \text{ VA}$ Rated voltage: $U_r = 230 \text{ V}$ Nominal frequency: $f_n = 50/60\text{Hz}$ Rated current: $I_r = \text{Detail see below on page 2}$ Initial short-circuit alternating current: $I_k = \text{Detail see below on page 2}$	
Certification scheme	P30VA01 Rev. 08/10.22	TÜV NORD: Procedural instruction for grid connection certification
Standards	VDE-AR-N 4105 2018-11	Generators connected to the low-voltage distribution network- Technical requirements for the connection to and parallel operation with low-voltage distribution networks
Additional standards	DIN VDE V 0124-100 2020-06	Grid integration of generator plants - Low-voltage - Test requirements for generator units to be connected to and operated in parallel with low-voltage distribution networks

$P_{AV,E}$ monitoring function is not integrated in the unit. The function can be implemented according to the specifications of the VDE-AR-N 4105 Chapter 5.5.2 in a stand-alone equipment.

The generating unit complies with the requirements contained in the certification programmes and standards and directives listed above, with restrictions. Further details and technical data can be found in the annex 1, consisting of 4 pages.

Registered No. 44 798 23053411
Assessment report no. 3537 1816

Validity
Notes: TYPE 1a CERTIFICATE

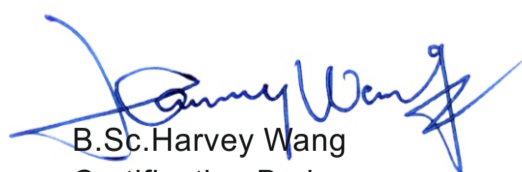

B.Sc. Harvey Wang
Certification Body
at TÜV NORD CERT GmbH

Essen, 2024-11-11
Rev. 1.0

TÜV NORD CERT GmbH Am TÜV 1 45307 Essen www.tuev-nord-cert.com gridcode@tuev-nord.de

ANNEX

Annex 1, Page 1 of 4

to Certificate Registration No. 44 798 23053411

Schematic structure

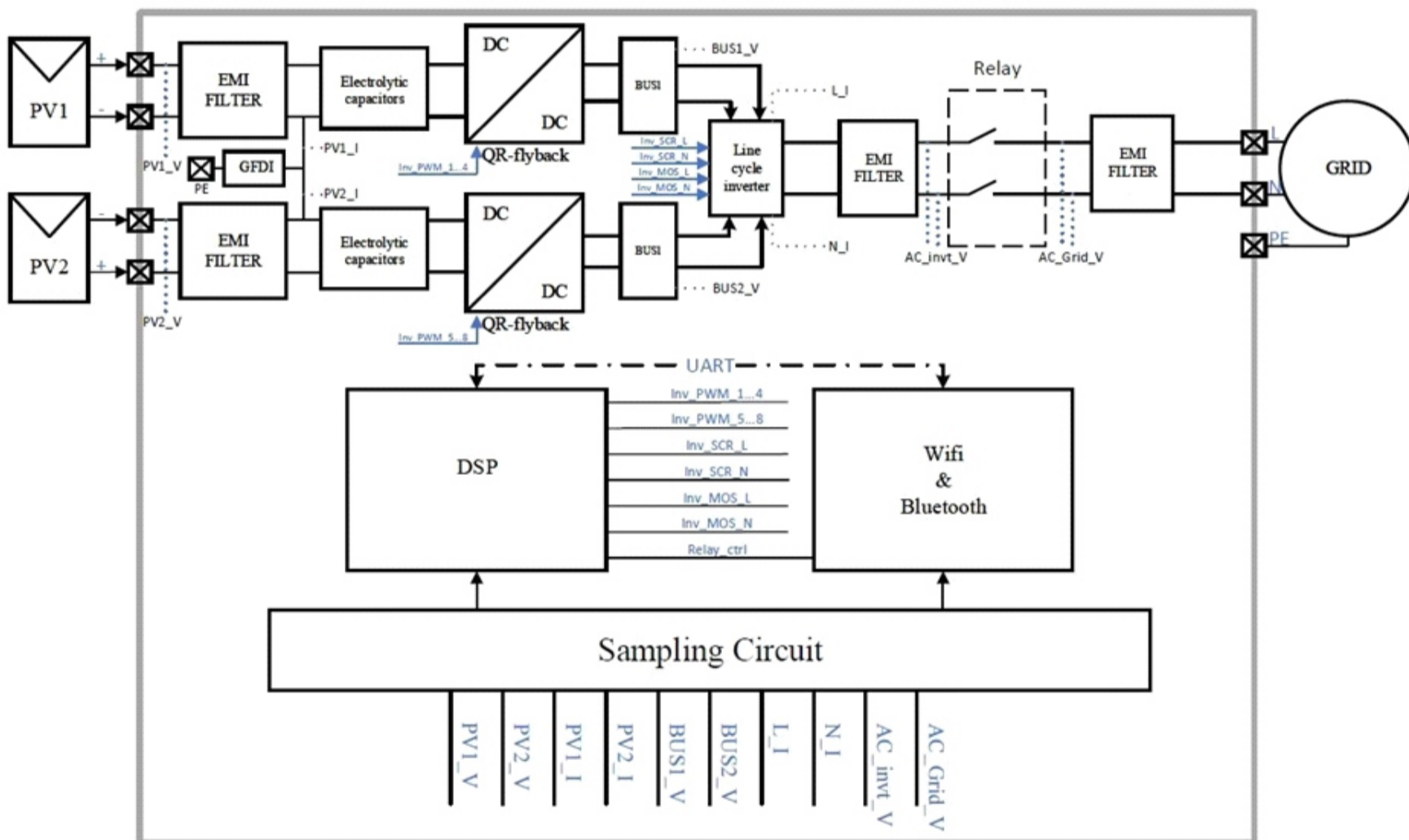

Harvey Wang
 B.Sc. Harvey Wang
 Certification Body
 at TÜV NORD CERT GmbH

Essen, 2024-11-11
 Rev. 1.0

TÜV NORD CERT GmbH

Am TÜV 1

45307 Essen

www.tuev-nord-cert.com

gridcode@tuev-nord.de

ANNEX

Annex 1, Page 2 of 4

to Certificate Registration No. 44 798 23053411

Technical Data

General information

General				
Type of EZE	Type 2 / PV Microinverter			
Designation	M1-1200-E	M1-1000-E	M1-800-E	M1-600-E
On-grid variables				
Rated apparent power S_{rE}	1200 VA 1200 VA(max)	1000 VA 1000 VA(max)	800 VA 800 VA(max)	600 VA 600 VA(max)
Rated effective power P_{rE}	1200 W 1200 W (max)	1000 W 1000 W (max)	800 W 800 W (max)	600 W 600 W (max)
Max. effective power P_{Emax}	1198 W (1.00 P_{Emax})	1004 W (1.00 P_{Emax})	801 W (1.00 P_{Emax})	601 W (1.00 P_{Emax})
Max. apparent power S_{Emax}	1213 VA (1.01 S_{Emax})	1008 VA (1.01 S_{Emax})	810 VA (1.01 S_{Emax})	605 VA (1.01 S_{Emax})
Rated voltage U_r	230 Va.c.			
Rated current I_r	5.22A	4.35A	3.48A	2.61A
Initial short-circuit alternating current I''_k	5.74A	4.79A	3.83A	2.87A
Reactive power adjustment range $\cos \varphi$	0.8 leading to 0.8 lagging			
Rated frequency f_n	50Hz/60Hz			
PV – Input Variables				
Min. MPP voltage	31V			
Max. MPP voltage	45V			
Max. DC input voltage	60V			
Number of MPPT	2			
Max. input current	20/20A			

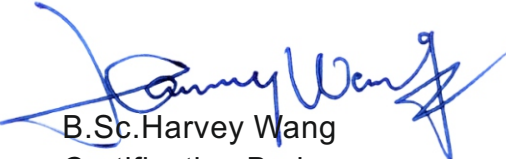
B.Sc. Harvey Wang
Certification Body
at TÜV NORD CERT GmbH

Essen, 2024-11-11
Rev. 1.0

TÜV NORD CERT GmbH

Am TÜV 1

45307 Essen

www.tuev-nord-cert.com

gridcode@tuev-nord.de

ANNEX

Annex 1, Page 3 of 4

to Certificate Registration No. 44 798 23053411

Isc PV	24/24A
DC – Input variables	
Type /MOS module	OSG80R140KF
Quantity DC Link Capacitor	8/8
Clock frequency	45Hz~60Hz
Type of power control	PWM
Max. Output current (only for MOS)	22A
Software versions	1.46
Generation unit Control	
Manufacturer	FOXESS CO., LTD.
Software version	1.46
Hardware version	1.7
Protection device	
Manufacturer	FOXESS CO., LTD.
Type	Integrated guard
Switch-off unit (AC)	HF140FF
Software versions	1.46

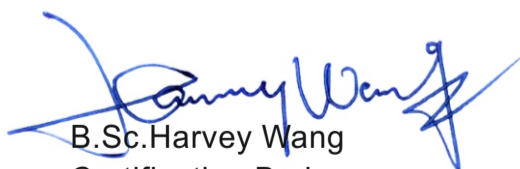

B.Sc. Harvey Wang
Certification Body
at TÜV NORD CERT GmbH

Essen, 2024-11-11
Rev. 1.0

TÜV NORD CERT GmbH

Am TÜV 1

45307 Essen

www.tuev-nord-cert.com

gridcode@tuev-nord.de

ANNEX

Annex 1, Page 4 of 4

to Certificate Registration No. 44 798 23053411

Notes

The manufacturer has proven for the manufacturing facility of the Unit a certification of its quality management system according to ISO 9001. The manufacturer confirmed in a manufacturer declaration that the certification of the management system will be valid parallel to the period of this unit certification.

Additional technical data, according to VDE-ARN 4105, are given in the assessment report (appendix A1).

The use of other firmware and software version numbers is allowed if the differences are proved and confirmed by TÜV NORD CERT GmbH beforehand. Validity of a new software version is attested by written confirmation and becomes part of the certificate.

The inverter have an integrated tie breaker and no central tie breaker. The specifications of VDE-AR-N 4105 for central NA protection in combinations with central or integrated tie switches must be observed and implemented at the level of the generating plant.

Restrictions

Please note that the Microinverter does not have a display. As a result, the protection settings of the decoupling protection and the connection conditions cannot be read or set via a display on the component. As a result, a readout function must be implemented on the PGU.

Appendix to the certificate

A1 Assessment report no. 35371816 version V1.0

A2 Extract from the test report (according to VDE AR-N 4105 annex E.5) TÜV NORD Testing (Suzhou) Co., Ltd., extract No. RDPVP05075/23B/01_R1 A1 from July .31, 2024

A3 Extract from the test report (according to VDE AR-N 4105 annex E.7) TÜV NORD Testing (Suzhou) Co., Ltd., extract No. RDPVP05075/23B/01_R1 A2 from July .31, 2024

A4 Manufacturer declaration for M1 series from 29.10.2024

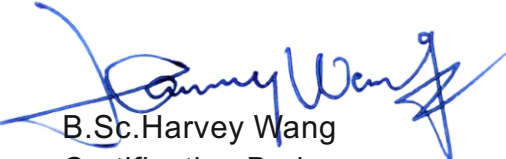
B.Sc. Harvey Wang
Certification Body
at TÜV NORD CERT GmbH

Essen, 2024-11-11
Rev. 1.0

TÜV NORD CERT GmbH

Am TÜV 1

45307 Essen

www.tuev-nord-cert.com

gridcode@tuev-nord.de